

***Low clearance  
High performance***



# *CME-55LC*

- Cummins diesel 120 horsepower engine
- Spindle torque rating up to 9,425 ft/lbs
- LC feed and retract system allows full operation in just 12 feet of overhead clearance
- Full 20 foot quick disconnect mast for normal operations
- Quickly converts to low clearance for limited overhead clearance situations
- CME automatic SPT hammer includes secondary lifting cylinder for low clearance operation
- CME-300 remote control driven rubber track carrier
- Truck and trailer mount options available

**CENTRAL MINE EQUIPMENT COMPANY**  
800-325-8827 • [info@cmeco.com](mailto:info@cmeco.com) • [www.cmeco.com](http://www.cmeco.com)



# CME-55LC



## Low clearance drill

### Power

Cummins QSF 3.8 L (229 cubic inch) Tier 4F turbocharged  
120 hp 4 cylinder diesel engine

### Carrier

Track width.....12 in. (30.5 cm) standard  
18 in. (45.7 cm) optional  
Avg. ground bearing pressure.....5.2 psi (.387 kg/cm<sup>2</sup>)  
Suspension.....triple walking beams  
Turning radius.....zero turn  
Drive.....hydraulic motor/planetary wheel drives  
Steering.....remote radio controlled  
Hydraulic front winch.....15,000 lb. (6,804 kg)  
Auger & rod racks.....standard  
Tool boxes.....standard

### Gradeability

Straight ahead climb.....50% grade  
Side-hill traverse.....36% grade

### Rotary Drive

Clutch, heavy duty.....13 inch (33 cm)  
Transmission.....5 speed forward, 1 speed reverse  
Rotary torque, standard .....7,780 foot pounds (10,548 Nm)  
Rotary speed, standard.....up to 800 rpm  
Rotary torque, high torque.....9,425 foot pounds (12,778 Nm)  
Rotary speed, high torque.....up to 665 rpm  
Hollow spindle I.D.....2 3/4 inch (7 cm) standard  
3 3/4 inch (9.5 cm) optional

### Hydraulic Feed System

Retract force.....27,615 pounds (12,525 Kg)  
Pulldown force.....19,750 pounds (8,958 Kg)  
Retract rate (max).....45 feet (13.7 m) per minute  
Rapid retract rate (max).....95 feet (29 m) per minute  
Feed rate (max).....65 feet (19.8 m) per minute  
Stroke.....72 inch (183 cm)

### Leveling System

Four hydraulic jacks, inverted design with chrome-plated  
piston rods enclosed at all times  
Stroke.....36 in. (91 cm)

### Weight (Approximate)

Empty.....18,500 lbs. (8,391 kg)

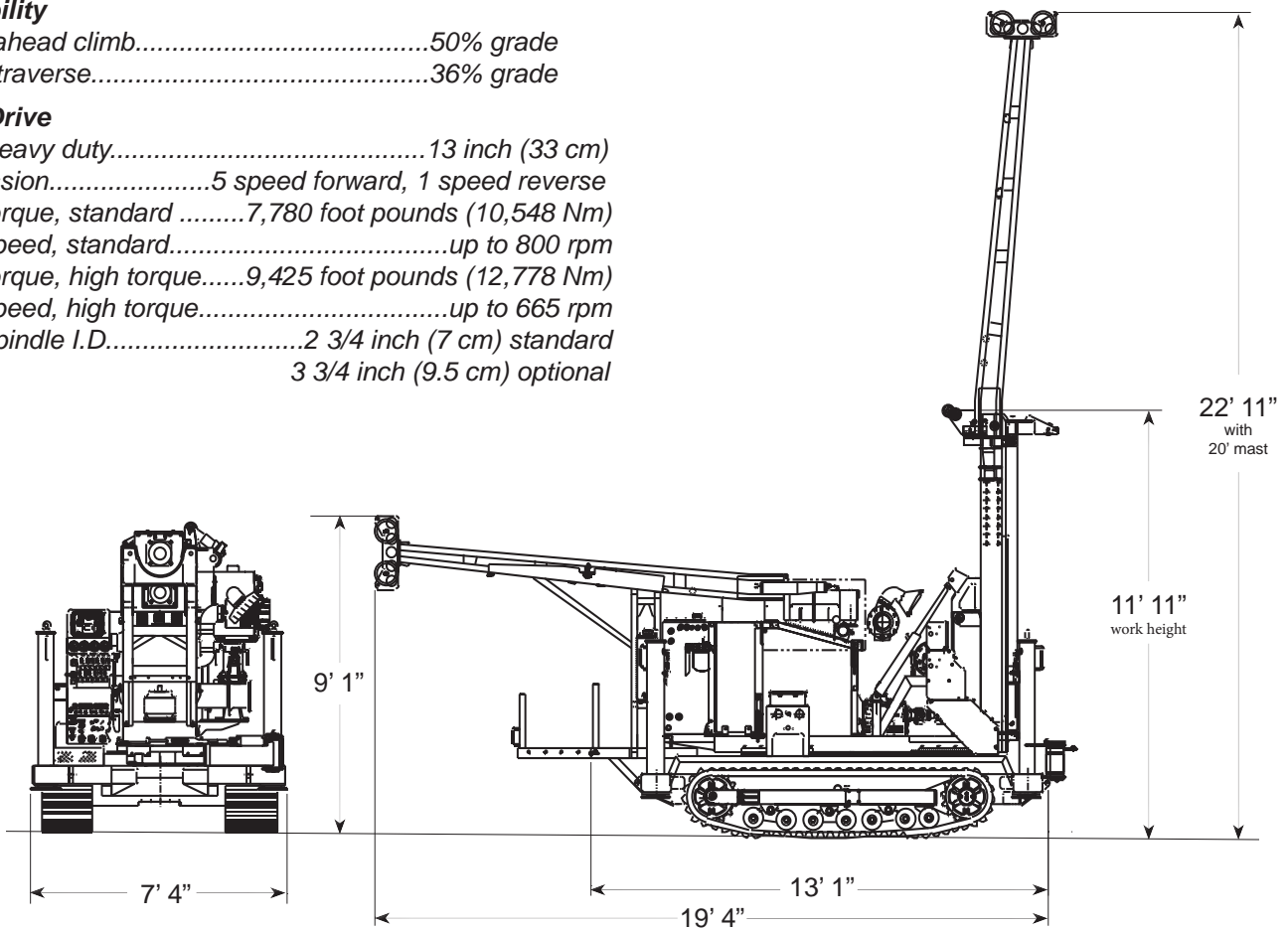

## CENTRAL MINE EQUIPMENT COMPANY

4215 Rider Trail North, Earth City (St. Louis), Missouri, 63045 USA

Phone: 314-291-7700 1-800-325-8827 FAX: 314-291-4880

E-mail: info@cmeco.com Website: www.cmeco.com

Performance ratings are based on engineering specifications, calculations and accepted industry standards. Capacities may vary according to drilling conditions.

CME reserves the right to amend these specifications at any time, without notice.

MKT 55LC 50 9/2024 Printed in USA

© Central Mine Equipment Company 2024