



CME-45B

- Cummins diesel 65 horsepower engine
- High torque rotary drive option rated at 4,875 ft/lbs
- Fixed vertical feed frame is ideal for pavement coring
- Detent feed with adjustable pulldown pressure and rate controls
- Available optional equipment includes automatic SPT hammer, direct push hammer and CPT options, hydraulic rod holder and break-out wrench, water pumps, water tank, a variety of hydraulic hoists, and much more
- No CDL required
- CME drills are custom built and painted to your specifications

CENTRAL MINE EQUIPMENT COMPANY
800-325-8827 • info@cmeco.com • www.cmeco.com



CME-45B



Power

Cummins QSF 2.8 (171 cubic inch) 65 Horsepower Tier-4f
4-cylinder turbocharged diesel engine

Hydraulic Feed System

Retract force.....19,600 pounds (8,890 Kg)
 Pulldown force.....13,650 pounds (6,192 Kg)
 Retract rate.....55 feet (17 m) per minute
 Feed rate.....79 feet (24 m) per minute
 Stroke.....68 inch (173 cm)

Rotary Drive

Clutch, heavy duty.....11 inch (28 cm)
 Transmission.....4 speed forward, 1 speed reverse
 Rotary torque, standard.....3,530 foot pounds (4,786 Nm)
 Rotary speed, standard.....up to 760 rpm
 Rotary torque, high torque...4,875 foot pounds (6,610 Nm)
 Rotary speed, high torque.....up to 550 rpm

Available Options

Mast Options

15 foot (4.6 m)
 18 foot (5.5 m)
 20 foot (6.0 m)

Hoist Options

1,800 pound (816 kg)
 3,200 pound (1,452 kg)
 5,000 pound (2,268 kg)
 Hydraulic wireline hoists

Hydraulic Rod Holder and Break-out Wrench Options

4 1/2 inch (11.4 cm) capacity
 5 1/2 inch (14 cm) capacity
 3 1/2 inch (8.9 cm) rod clamp and
 break-out wrench

CME Automatic Hammer System Options

110 pound (49.9 kg)
 140 pound (63.5 kg)
 170 pound (77.1 kg)
 300 pound (136.1 kg)
 340 pound (154.2 kg)

Water Pump Options

Moyno 3L6 - 36 gpm/225 psi (136 lpm/1,551 kPa)
 Moyno 3L8 - 84 gpm/225 psi (318 lpm/1,551 kPa)
 Bean L09 (420) - 25 gpm/500 psi (95 lpm/3,448 kPa)
 Bean L1122 (435) - 35 gpm/500 psi (132 lpm/3,448 kPa)
 Bredel Hose Pumps

Drill Platform Options

Special lighting, including work lights and strobes
 Rod, auger and core barrel racks
 Tool Boxes
 Work tables
 Pipe vises
 Water tanks

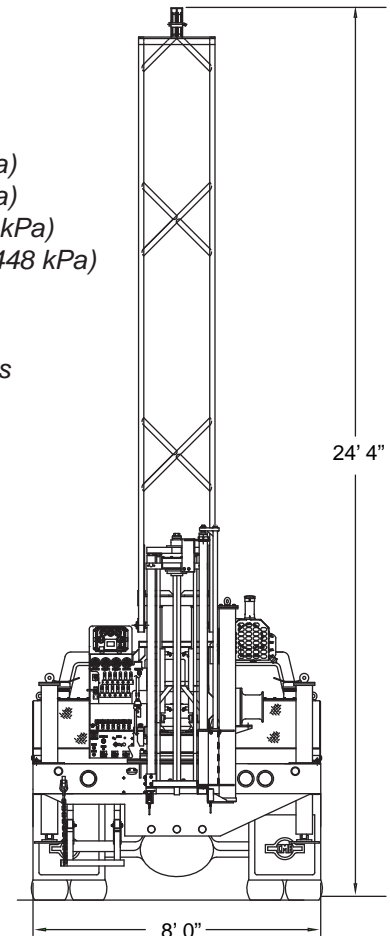
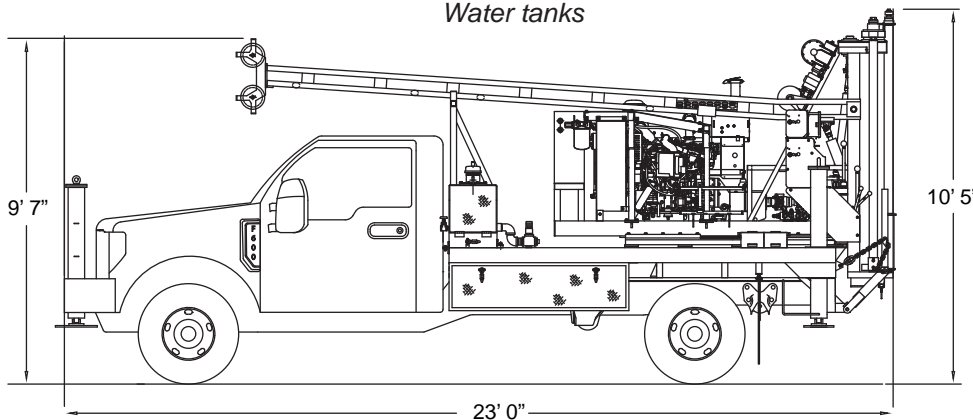

Typical truck mount configuration with optional 20 foot mast. Dimensions will vary, depending on truck wheelbase and options.



CENTRAL MINE EQUIPMENT COMPANY

4215 Rider Trail North, Earth City (St. Louis), Missouri, 63045 USA
 Phone: 314-291-7700 1-800-325-8827 FAX: 314-291-4880
 E-mail: info@cmeco.com Website: www.cmeco.com

Performance ratings are based on engineering specifications, calculations and accepted industry standards. Capacities may vary according to drilling conditions.
 CME reserves the right to amend these specifications at any time, without notice.

MKT 45B 100 7/2023 Printed in USA
 © Central Mine Equipment Company 2023